

FOOD LION FRONT-END FRONTLOADER PROGRAM ART SPECIFICATIONS

MATERIALS:

All preliminary creative (color proofs) must be forwarded to the [FrontLine Production Traffic Manager at creativdepartment@frontmark.com](mailto:creativdepartment@frontmark.com) for approval, prior to delivery of final artwork.

Mac files are required for all FrontLine programs. IBM/PC formats can be converted for an additional charge. Accepted Mac formatted media includes Zip 100 & 250, CD-R, CD-RW, 3.5 floppy and DVD. All current Mac programs are supported but Illustrator, Quark Xpress, PhotoShop and InDesign are preferred.

Please submit artwork for ads and headercards on a separate disk from artwork for FrontLoader program. When submitting art on disk, all documents should include all working (layered) files, supporting fonts, illustrations and scans. All submitted fonts should be Postscript in nature. Do not use 'True Type' fonts or stylized fonts in Quark. Illustrator files should have all fonts converted to outlines.

Send a disk directory with laser or color proof for each ad. All images and or files should be 300DPI and converted to CMYK before sending. For further technical information, contact the [FrontLine Production Traffic Manager at creativdepartment@frontmark.com](mailto:creativdepartment@frontmark.com).

DELIVERY:

Send Preliminary color proof to creativdepartment@frontmark.com

Final Creative must be sent on a CD along with Color Proofs to:

FrontLine Marketing
 10 Corbin Drive - 3rd Floor
 Darien, CT. 06820
 Attn: Production Traffic Manager.

FOOD LION FRONT-END FRONTLOADER

MECHANICAL SPECS:

Printing Process: Offset printing on litho sheet and mounted on white e-flute

Trim Size: (Finished Size): 4" D x 8" W x 13" H (Height can be shorter than 13" but no higher)

Bleed: ¼" Bleed on all sides

LIVE AREA: 4" D X 8" W X 13" H

4C SCREEN: 150 LINE SCREEN

Colors Available: 4-color process (additional colors are subject to extra charge)

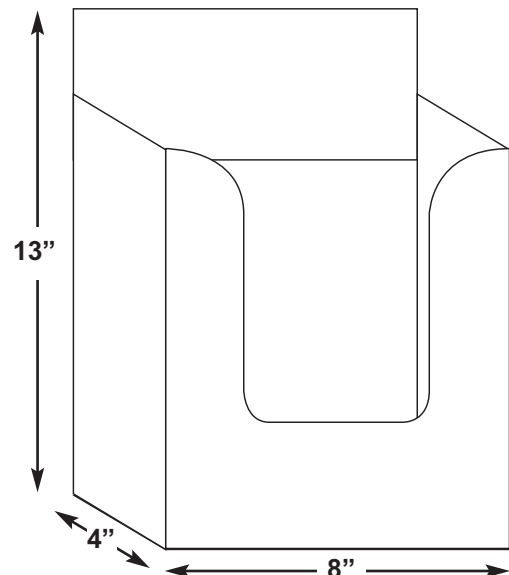

Note: FrontLoader can be multi-tiered and include J-Hooks as long as the dimensions of the FrontLoader remain 4" D x 8" W x 13" H.

FRONT-END FRONTLOADER PROGRAM ART SPECIFICATIONS

MATERIALS:

All preliminary creative (color proofs) must be forwarded to the [FrontLine Production Traffic Manager at creativedepartment@frontmark.com](mailto:creativedepartment@frontmark.com) for approval, prior to delivery of final artwork.

Mac files are required for all FrontLine programs. IBM/PC formats can be converted for an additional charge. Accepted Mac formatted media includes Zip 100 & 250, CD-R, CD-RW, 3.5 floppy and DVD. All current Mac programs are supported but Illustrator, Quark Xpress, PhotoShop and InDesign are preferred.

Please submit artwork for ads and headercards on a separate disk from artwork for FrontLoader program. When submitting art on disk, all documents should include all working (layered) files, supporting fonts, illustrations and scans. All submitted fonts should be Postscript in nature. Do not use 'True Type' fonts or stylized fonts in Quark. Illustrator files should have all fonts converted to outlines.

Send a disk directory with laser or color proof for each ad. All images and or files should be 300DPI and converted to CMYK before sending. For further technical information, contact the [FrontLine Production Traffic Manager at creativedepartment@frontmark.com](mailto:creativedepartment@frontmark.com).

DELIVERY:

Send Preliminary color proof to creativedepartment@frontmark.com

Final Creative must be sent on a CD along with Color Proofs to:

FrontLine Marketing
10 Corbin Drive - 3rd Floor
Darien, CT. 06820
Attn: Production Traffic Manager.

FRONT-END FRONTLOADER (RALPHS & WINN DIXIE)

MECHANICAL SPECS:

Printing Process: Offset printing on litho sheet and mounted on white e-flute

Trim Size: (Finished Size): 6" D x 6" W x 13" H (Height can be shorter than 13" but no higher)

Bleed: ¼" Bleed on all sides

LIVE AREA: 6" D X 6" W X 13" H

4C SCREEN: 150 LINE SCREEN

Colors Available: 4-color process (additional colors are subject to extra charge)

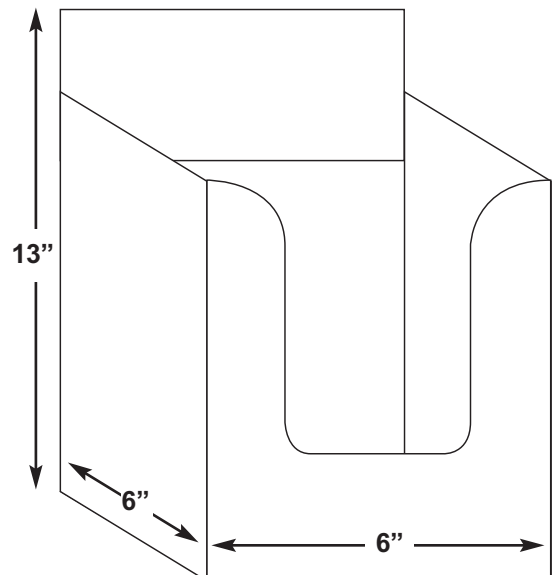

Note: FrontLoader can be multi-tiered and include J-Hooks as long as the dimensions of the FrontLoader remain 6" D x 6" W x 13" H.